

The SHUROUQ Collection FROMM. magazine



FROMM.

The SHUROUQ
Collection
FROMM.magazine

FROMM.
2022

VOL.0

Letter from Founder & CEO
Alia Rachid



From an idea sparked amongst peers to where we are today, it has been an exhilarating journey that started slightly over a year ago. Today, FROMM. has established its presence, expanded its team, and enriched invaluable experiences collectively, all with the single mission to inaugurate collections that are cultivated by the rich heritages of local design communities, and allowing space for innovation by providing the expertise in great design and impeccable manufacturing.

As a result, today FROMM. has created a collaborative design platform and a talent incubator with evolving resources. Our dedication to production quality and sustainability is driven by a laudable team enriched with industry experience. FROMM. is proud today to launch its first collection, "The Shurouq Collection". The word "Shurouq" is an Arabic word that translates to "Dawn", which not only embodies part of the inspiration behind this collection but also where FROMM. is as a company.

FROMM. is at its dawn and has a long journey ahead. We hope to usher in a new era in design culture that focuses not only on the end product but on the design process, orientation, and collaboration, that stand behind each collection. This focus enables FROMM. to create collections that allow innovation of traditional heritage to exist in any environment or living space.

I would like to take this opportunity to show my gratitude and personally thank the FROMM. Team and our extended international support team. This would not have been possible without our collective determination and harmonious collaboration. This collection marks a major milestone on our journey and represents the first step of many in achieving our mission.

On behalf of both myself and FROMM., I would like to invite you to immerse yourself in The Shurouq Collection, visualize the designer's inspirations, and let this collection enrich your living spaces.

A handwritten signature in black ink, which appears to read "Alia Rachid". The signature is fluid and cursive, written in a professional style.

INDEX

1	INTRODUCTION	08
1.1	WHO IS FROMM.	11
1.2	FROMM. LAB WORKSHOPS	12
1.3	HERITAGE & INNOVATION	16
1.4	From MSHEIREB to THE WORLD	18
1.5	SUSTAINABILITY	22
2	DESIGN PROCESS	24
2.1	FROMM. DESIGN PROCESS	26
3	THE SHUROUQ COLLECTION	30
3.1	CONCEPT	35
3.2	FROMM. DESIGNERS	36
3.3	SHUROUQ COLLECTION	40
3.3.1	HAIMA' هَيْمَاء Armchair & Pouf	42
3.3.2	MAJRA مَجْرَى Multifunctional Table	48
3.3.3	BAIDA' بَيْدَاء Sofa	52
3.3.4	MAKTABA مَكْتَبَة Wall Unit	56
3.3.5	DERJ دَرْج Console Desk	60
3.3.6	MAIZ مَيْز Coffee Table	64
3.3.7	TAWLA طَاوَلَة Side Table	68
3.3.8	LAITE لَيْت Floor Lamp	72
4	FROMM. END	76
4.1	CONCLUSION	79
4.2	MEET THE FROMM. TEAM	80
4.3	CONTACT US	82

1 INTRODUCTION



1.1 WHO IS FROMM.

FROMM. is a design platform and company launched between Qatar and Italy to create the ideal fusion of Design and Manufacturing, connecting the local, Italian and international design communities to the global market.

The name "FROMM." derives from the origin of the collections and the start of our journey as a company and platform. FROMM. was founded in Doha, Qatar, and is headquartered and operates out of M7, Msheireb. The additional "M" in the name represents Msheireb, and thus as we grow as a company and platform, so does our story and pride that is our origin.

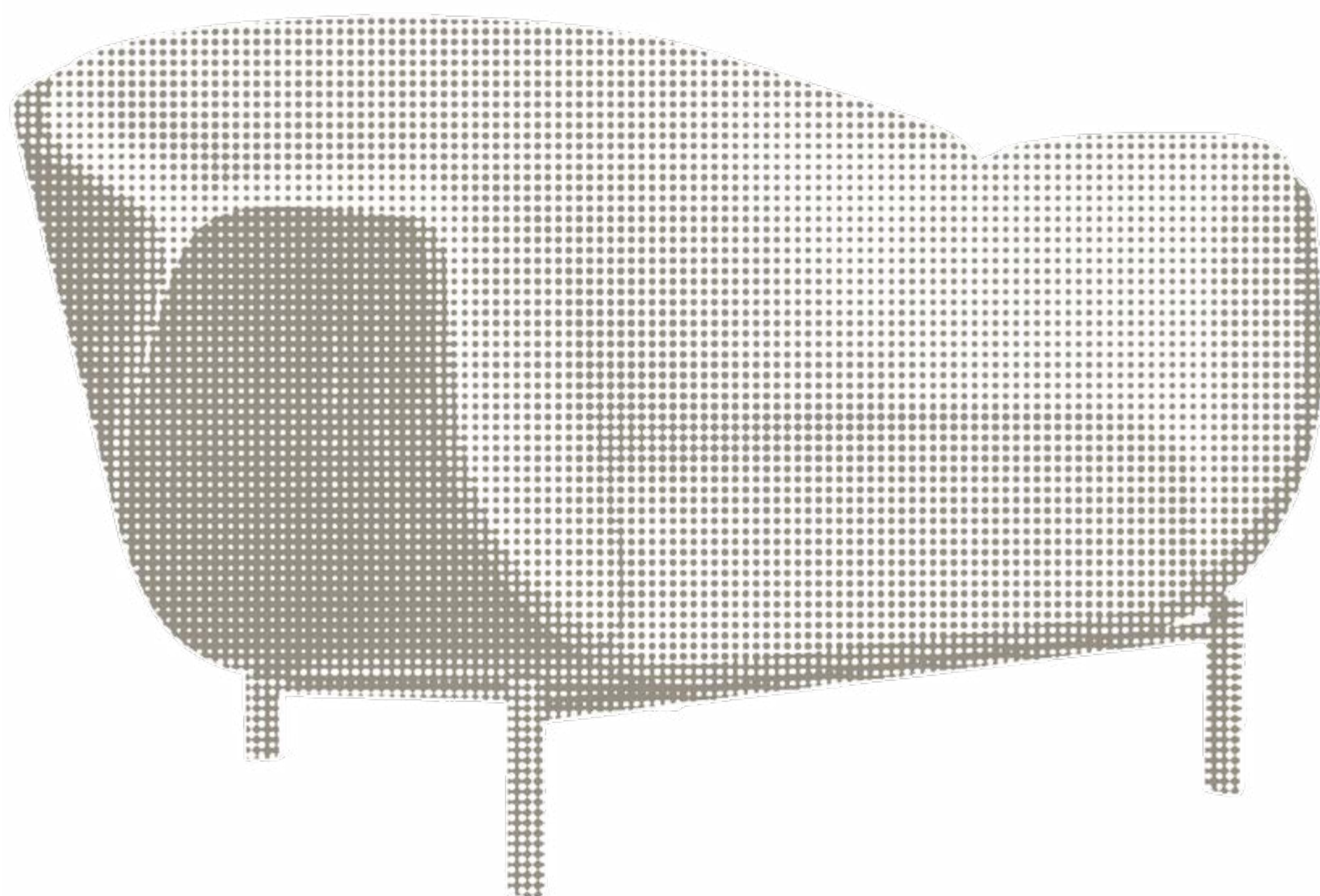

1.2 FROMM. LAB



Render of upcoming FROMM. Lab office space, M7 Building, Msheireb, Doha.

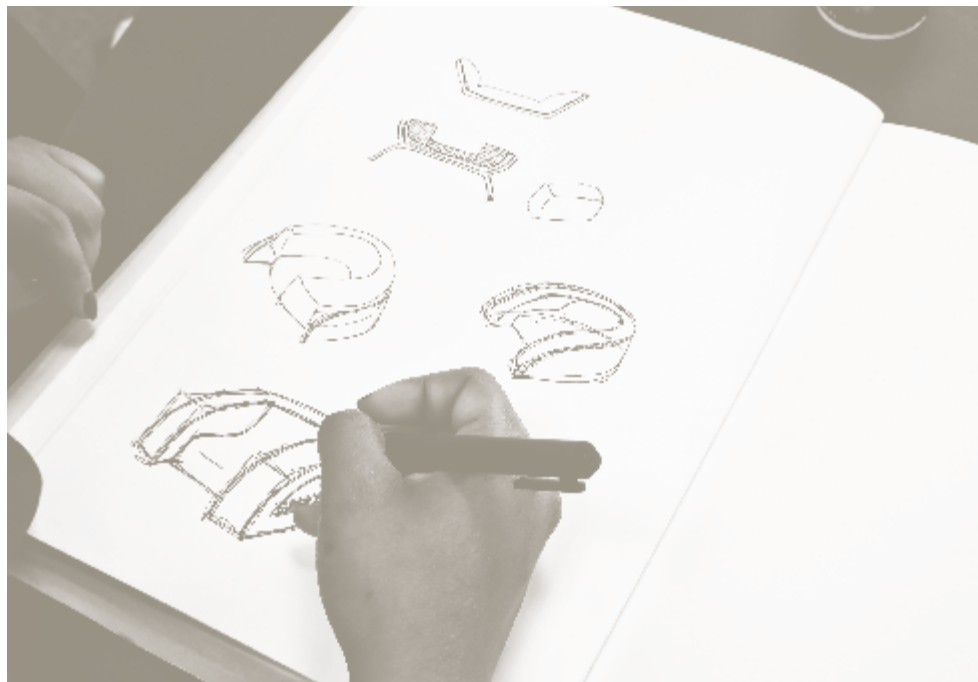

Nov. 15, 2021. Shurouq Collection Designer Shua'a Ali sketching initial collection designs in FROMM. Lab Workshop.

FROMM. is a design platform that acts as a talent incubator for aspiring designers. We receive designers at different stages, from different backgrounds, and with different goals. Our job as a design platform and incubator is to recognize the designer's strengths and creativity to help them capitalize on them in a way that can appeal to a global market.

WORKSHOPS

Designers are taken through a rigorous process we call the "FROMM. Design Process," where ideas are pushed to their limits, creative inspirations are tested, prototyped and final designs are produced.

At the core of this process lies FROMM.'s "three COs": **collaborate, co-design and co-create**. The three COs are at the heart of our design process and play a guiding role in all our work.



Nov. 15, 2021. Shurouq Collection Designer Shua'a Ali in FROMM. Lab workshop with FROMM. Qatari-Italian team including FROMM. Brand Manager, Dana Said and FROMM. Design Manager, Matteo Squaiella.

FROMM. provides these designers a unique opportunity, through our world-class resources and design infrastructure, to produce or contribute to collections that are sold on the global design market and showcased at the largest events in our industry.

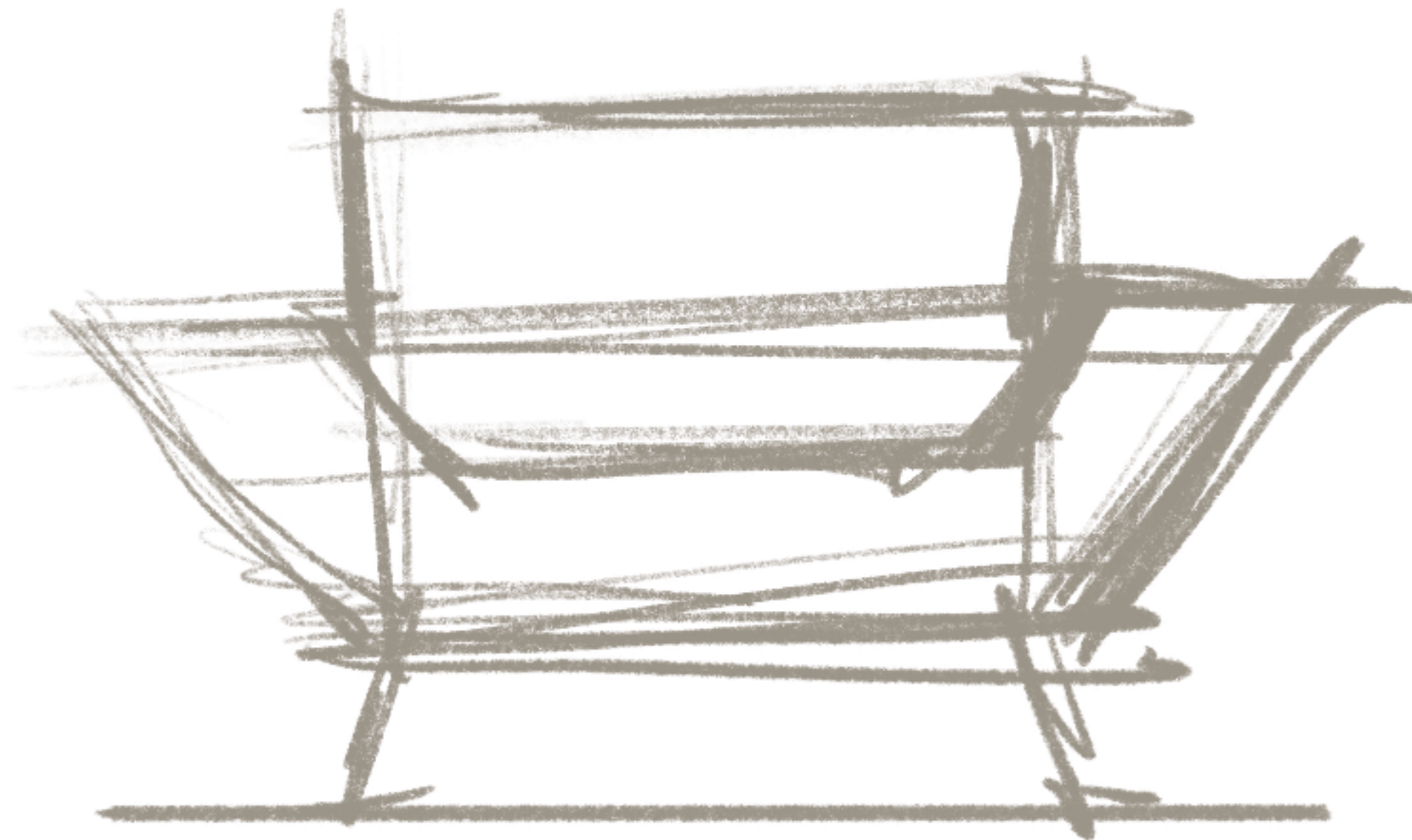

In relation to our mission statement, education is at the core of what we do. At FROMM. we recognize that today's aspiring designers are tomorrow's industry leaders. Therefore, we are actively investing our resources in cultivating untapped talent to provide fresh perspectives to our industry that are rooted in heritage innovation.

FROMM. supports local, aspiring designers and takes it a step further by bridging the gap between Milan design culture and local design culture in an effort to support the local design ecosystem more broadly.

Milan is the global capital of design culture. For this reason, FROMM. is committed to ensuring the exclusive collections and pieces designed locally are showcased, marketed, and exhibited in Milan. Bridging local design culture with Milan will provide the foundation needed for the local design cultures to flourish.

1.3 HERITAGE & INNOVATION

Commercially, FROMM. aims to provide a new perspective on furniture rooted in heritage innovation. We look to be inspired by traditions, culture, customs, and heritage more broadly to create one-of-a-kind pieces that are stunning, thought-evoking, and functional.

The collections and pieces designed by FROMM. are luxury products, statement pieces that stand out in any living space. To own a FROMM. piece is to own a piece of international design culture rooted in a localized heritage. FROMM. provides the market with exclusive pieces that champion local designers and support the next generation of designers.



Doha, Qatar. Fort Zubarah, a historical military fortress built in 1938 and a UNESCO World Heritage Site, showcasing Qatari heritage through architecture.

Our transparent design and fabrication processes allow clients to understand the impactful labour behind each piece, from the sketch pad to their living spaces. By choosing FROMM. people prioritize innovation, sustainability, and the support of aspiring designers, in living spaces. The FROMM. community represents a forward-thinking, design-focused group of creatives that do not settle when it comes to quality and design.



Doha, Qatar. Museum of Islamic Arts built in 2008, showcases a great display of heritage innovation through Islamic architecture.

1.4 From MSHEIREB

MSHEIREB

FROMM. is headquartered in Doha, Qatar. Our office is housed in the M7 building, located in Msheireb, Doha. M7 is Qatar's epicenter for innovation and entrepreneurship in design, fashion, and tech.

WORLDWIDE

Through our global network, we are able to ensure that we are producing and manufacturing each piece and each collection where it can be best produced, leveraging the talents and strengths of each region in our global network.

to THE WORLD

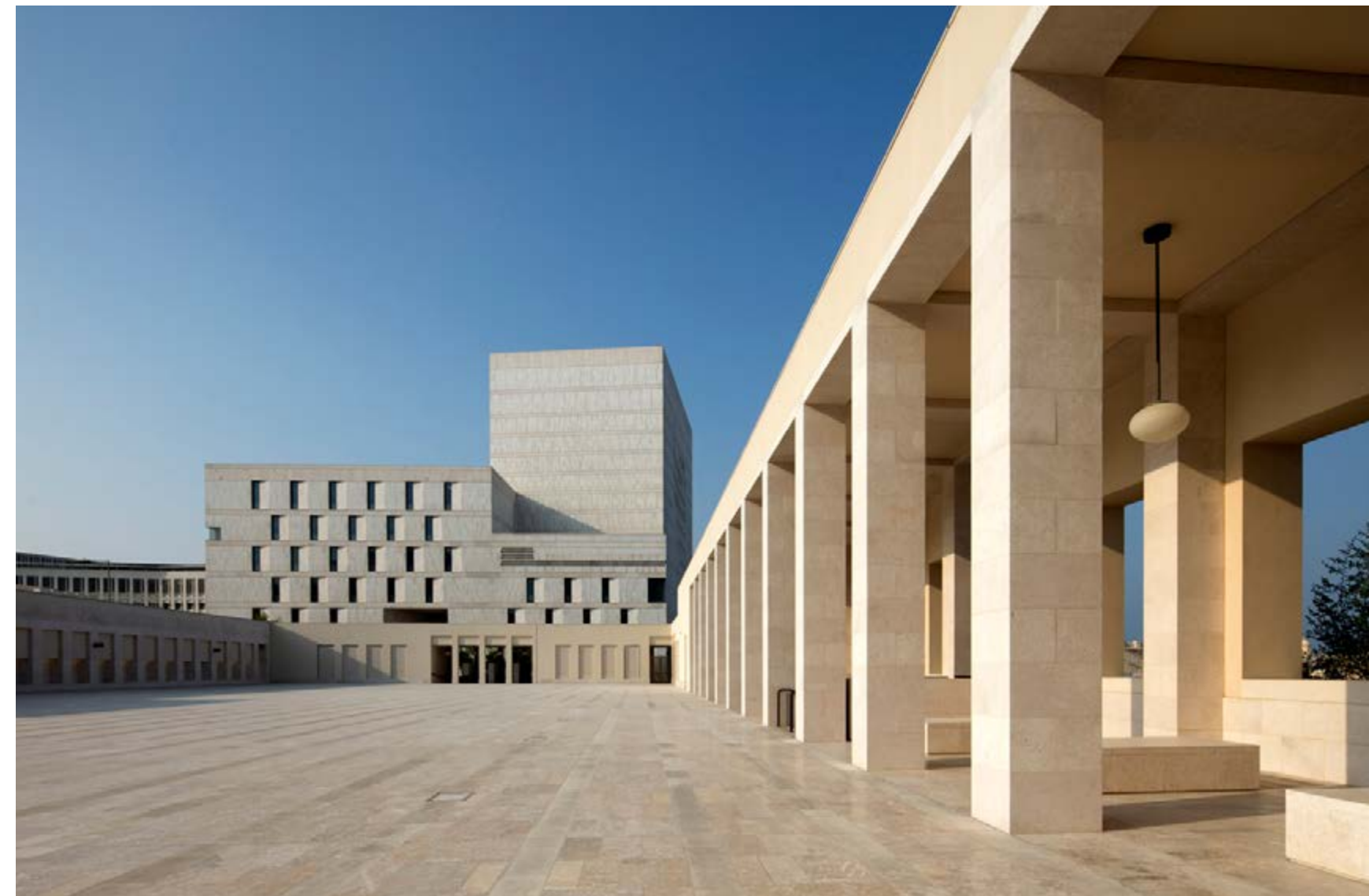

Msherieb, Doha, Qatar. Doha's downtown regeneration project that demonstrates heritage innovation through architecture.

MILAN

FROMM.'s first global showroom, exhibition space and FROMM. Lab is located in the Zona Tortona District, Milan, Italy. Zona Tortona represents one of Milan's most relevant design districts, rich in history and culture, still influential today.

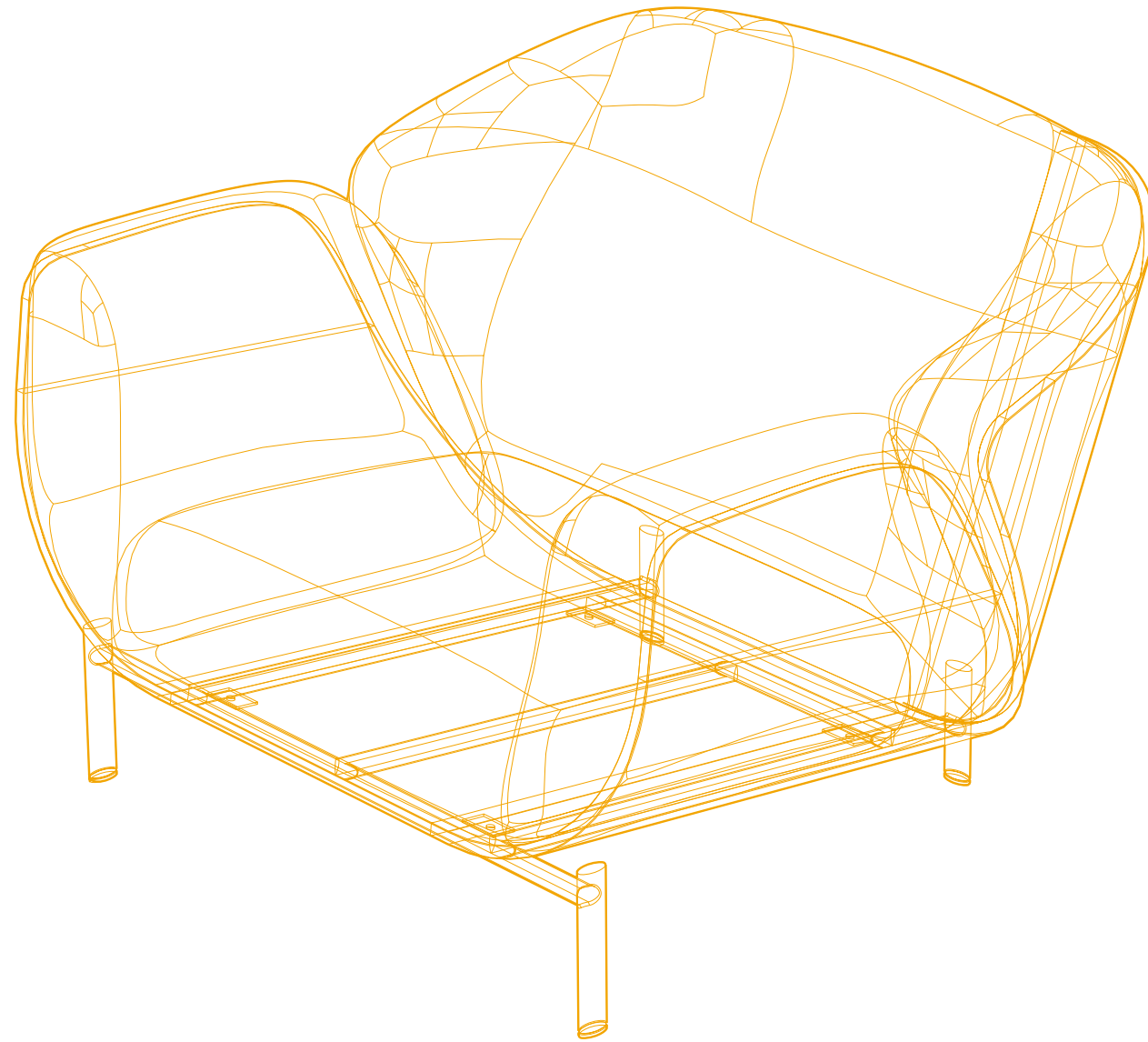

BRIANZA

FROMM.'s production and manufacturing process is rooted in value engineering that guarantees the best production without sacrificing on aesthetics and functionality. We strive to provide the highest quality products to our clients. The production and manufacturing of our collections and pieces are actioned through our global network of suppliers, master craftsmen, and interior architects.

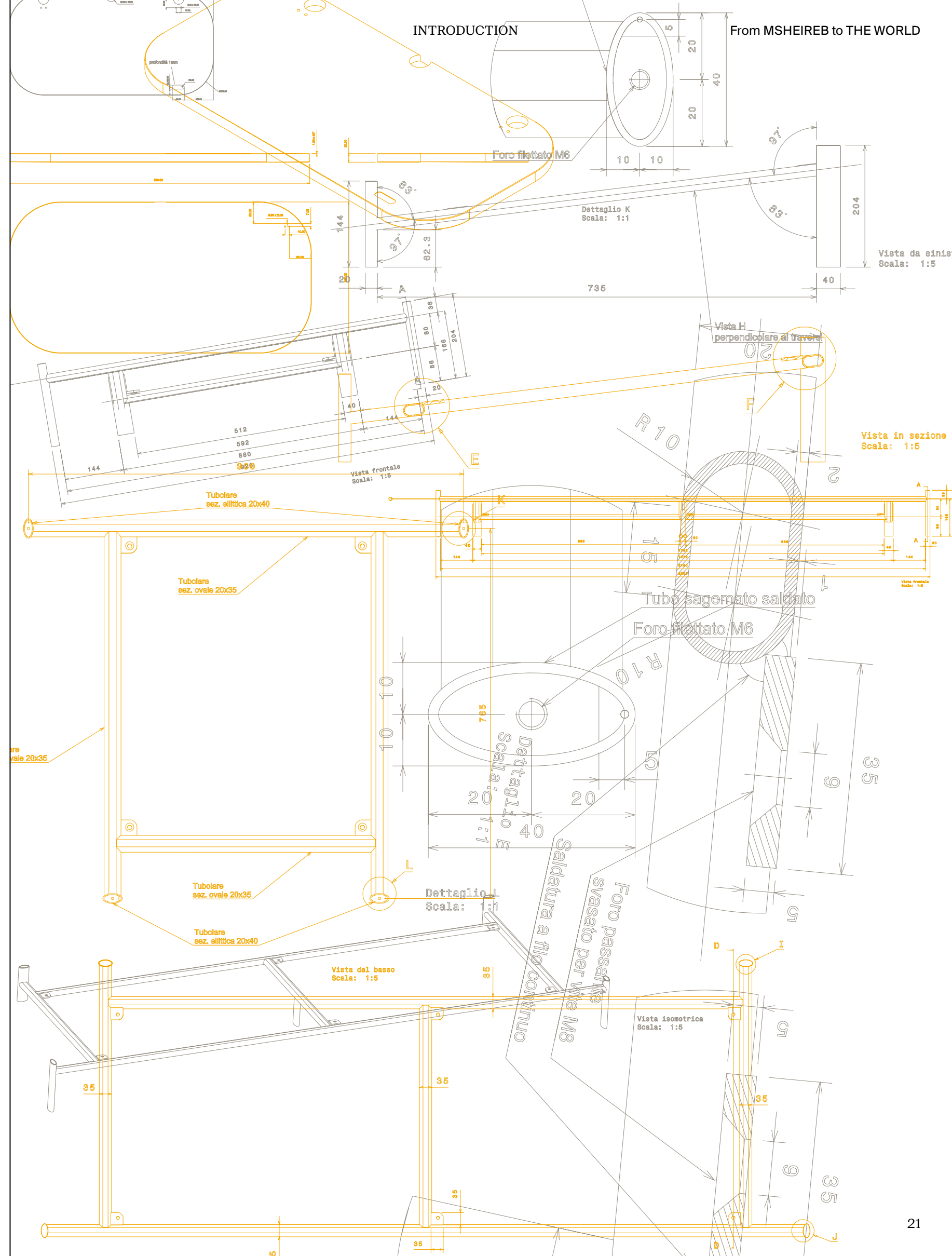

1.5 SUSTAINABILITY

FROMM. strives to be sustainable in every endeavor, as sustainability serves as one of FROMM.'s core values. Moreover, FROMM. has committed to respecting our shared environment, culture, and communities.

SOCIAL SUSTAINABILITY

FROMM. is highly mindful of its business practices and impact on the larger team, their equity, and well being. Working with aspiring designers, FROMM. ensures the contribution of designers is awarded justly. FROMM. strives to create functional and comfortable working environments that are supported, safe and secure for all parties involved.

CULTURAL SUSTAINABILITY

In the age of globalization and cultural assimilation, at FROMM. we aim to preserve culture. Innovating heritage is at the core of what FROMM. does. We mindfully approach this mission by walking the thin line between building on the existing heritage and creating collections that are appealing in an international context.

MATERIAL SUSTAINABILITY

FROMM. is dedicated to sourcing materials, finishes, and solutions in line with global sustainability standards. Moreover, FROMM. creates inherently sustainable pieces that are made to stand the test of time.

We have demonstrated this sustainability focus in the Shurouq Collection by using the following materials:

PLYWOOD

Among the plywood materials used in the Shurouq Collection is MW ECOZERO® plywood. This plywood stands out for being formaldehyde-free; the veneer is manufactured using formaldehyde-free glues. As formaldehyde is a toxic, flammable chemical and a common air pollutant, MW ECOZERO® plywood can be considered a highly sustainable material.

ECO LEATHER

All Eco-leather elements in the Shurouq Collection are made using sustainable, animal-free materials that are fabricated through a sustainable process.

PADDING

The padding used in the Shurouq collection is a combination of expanded polyurethane, which, despite its synthetic origin, is a highly durable and resistant material. It can be easily divided from other materials and recycled at the end of its long life cycle. The second part of this combination is the soft fiber padding, made from recycled bottles and used to cover the expanded polyurethane.

PACKAGING

FROMM. will outsource product shipment to packaging companies that use green solutions, consistent with our sustainable approach. Both boxes and inner shockproof materials will be created using recycled cardboard. The ink used to mark these boxes will be employed minimally, thus cutting down our impact on the environment.

2

DESIGN PROCESS



2 FROMM. DESIGN

The FROMM. Design Process is a unique approach to mentoring and collaborating with designers, taking them through a comprehensive design journey, starting from a sketch to a real-life product.

The process offers aspiring designers a guided experience and opportunity to turn their creative ideas into real furniture pieces and products to be showcased in the local and international markets.

FROMM. Design Process is distinctively holistic and human-centered: it starts with research, education, co-designed mentorship, ending with international sourcing, product value development, manufacturing and distribution.

FROMM. follows nine design steps:

**Market Research Brief
Collaborative Design Process
Production Testing Log**

Before the commencement of the project, the Qatar team and Milan team work closely to outline the brief and the structure for each project to determine the best outcome for the designers.

PROCESS

The projects are structured in a competition format where designers are guided through various phases. A selection process based on specific criteria follows, where designers are evaluated based on their designs and creativity. Once finalized, the Qatar & Milan teams work together to go through finalist submissions, starting by looking over the designers' inspirations and questioning their creative decisions.

During the prototyping phase of this process, designs are put through various testing exercises that include but are not limited to ergonomic testing and technical troubleshooting to create design products that are highly engineered and fit for both local and international markets. At the core of this process is our intensive workshops that take place in the FROMM. Lab.

**Concept Co-Research
Process Prototyping
Statistics Sales Distribution**

These workshops study designers' design direction to enable them to reach the best possible final product with respect to functionality & durability. Finally, the final product is then taken through the best sales channels.

FQATAR
FRMSHEIREB
FROMMILAN
FROMBRIANZA
FROMMMWORLDWIDE
FROMM.HERITAGE
FROMMCO-DESIGN
FROMMCO-CREATE
FROMCOLLABORATE
FRGLOCAL
FGENERATION
FMAJLIS
FRPERSPECTIVE
FROMPRODUCTION
FROMMARKETING
FROMMBRIEF
FROMM.EDUCATION

NATURE.MMORF
ECOSYSTEMMMMOF
PROCESSMOF
PROTOTYPINGOF
INTERNATIONALF
RESPONSIBILITYF
SUSTAINABILITYF
INNOVATIONOF
RESEARCHMOF
STRATEGYMMOF
NETWORK.MMOF
PLATFORM.MMOF
LABMMOF
TORTONAMOF
TALENTSOF
DESIGNERSF
SPACEF

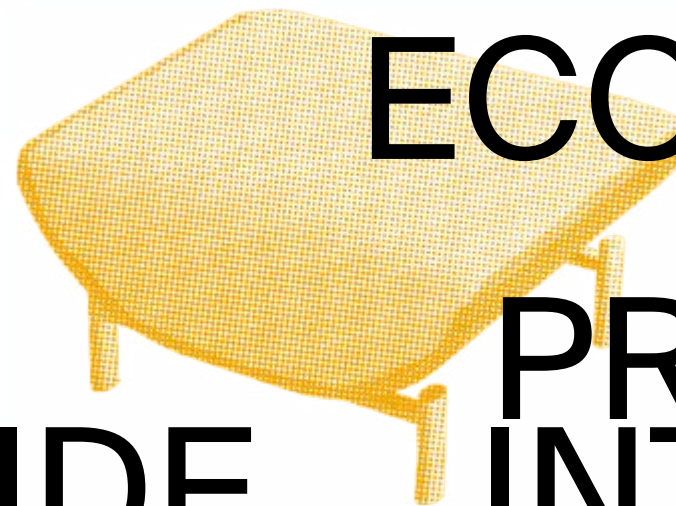

3 THE SHUROUQ COLLECTION

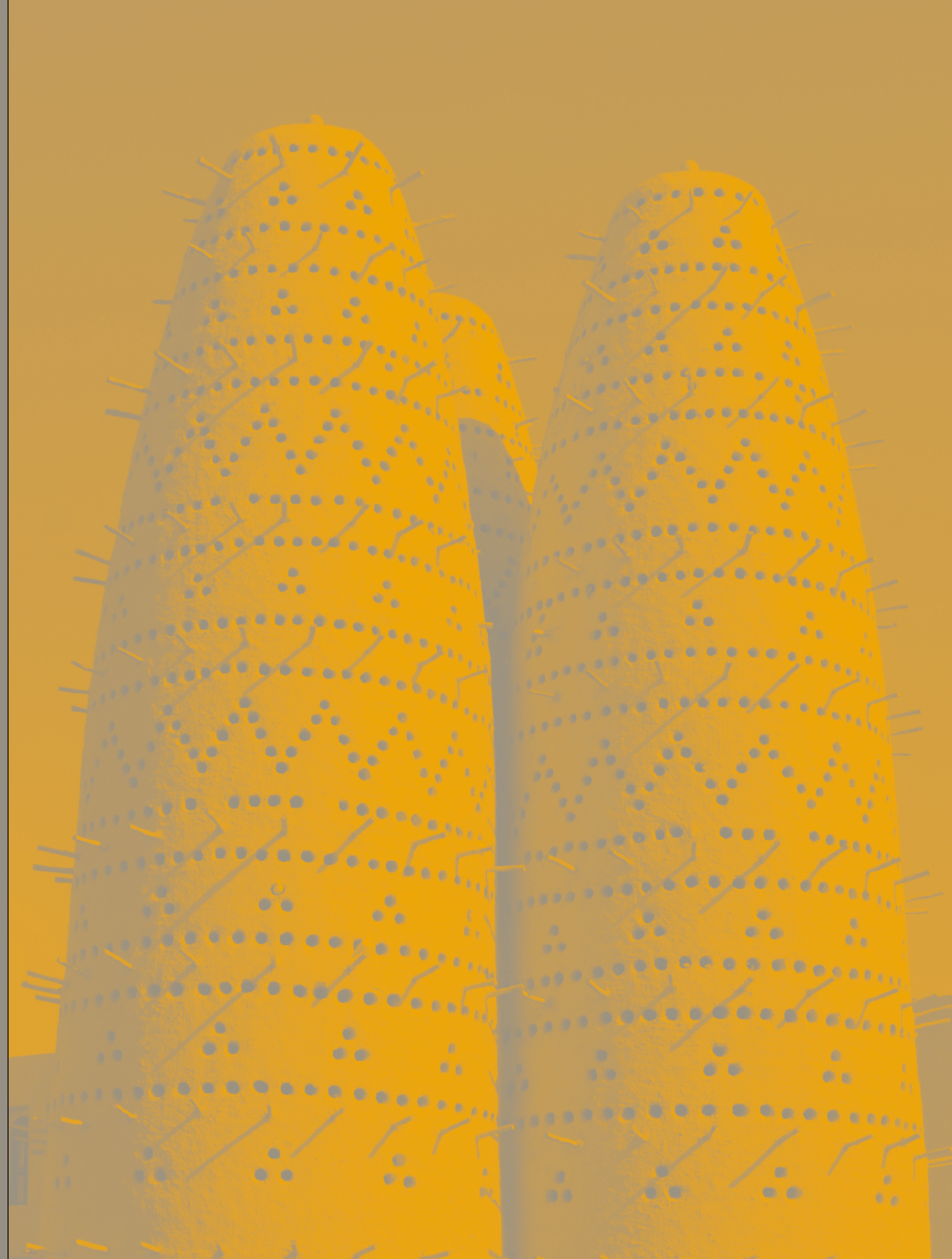

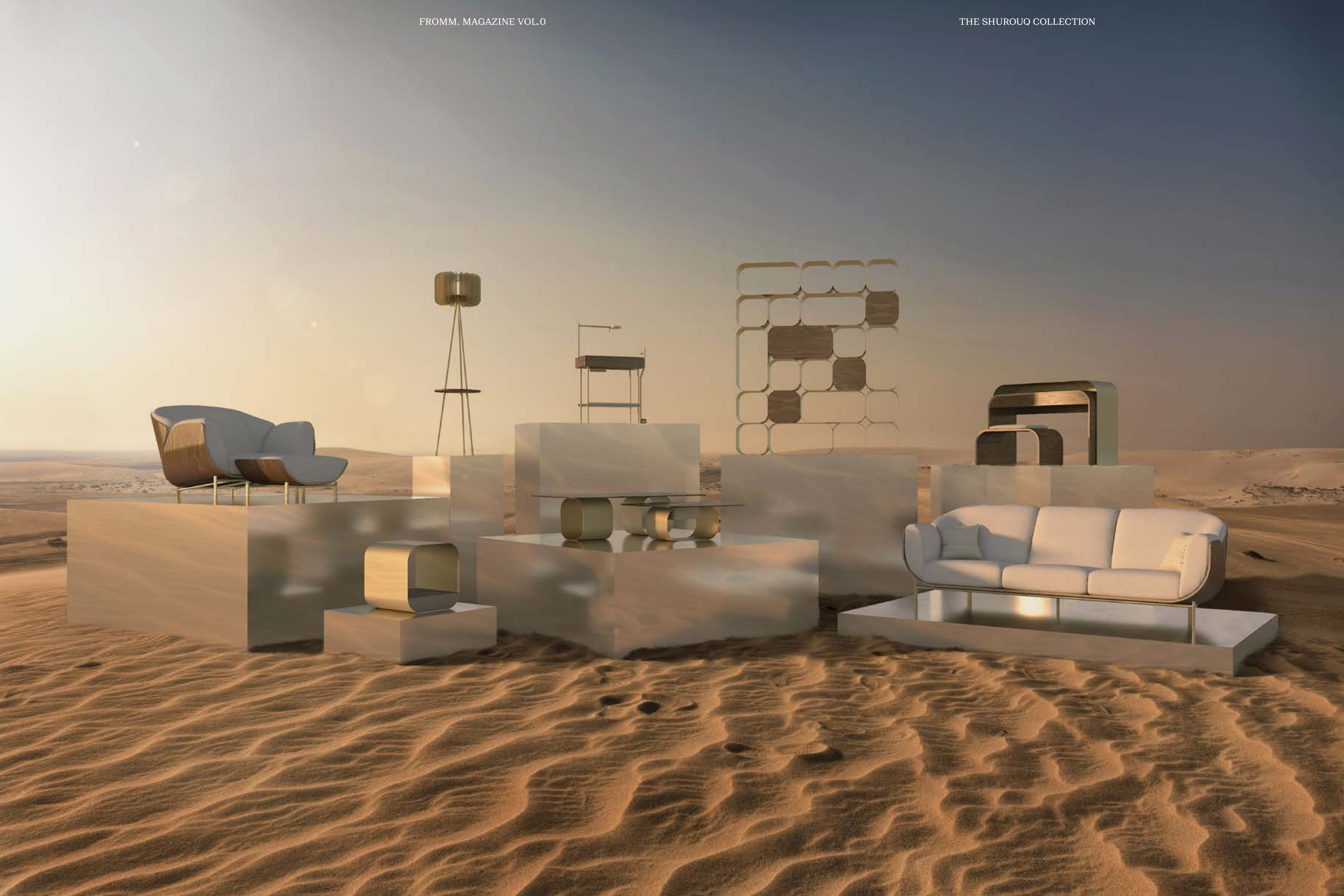

3.1 CONCEPT

FROMM. is proud to launch the Shurouq Collection. The Arabic word “Shurouq” translates to “Dawn”, which not only embodies part of the inspiration behind this collection but also where FROMM. is as a company, at the dawn of its journey. The dawn inspiration shines bright in the Shurouq Collection through the varying and widely employed gold tones and nuances.

Through the curves and waves that mimic the sand movement in the desert, the Shurouq Collection recalls the sand dunes and the breathtaking desert scenery, its source of inspiration.

The Shurouq Collection’s pivotal inspiration was the “Majlis” living space. The Majlis is a cornerstone of Qatari heritage, especially typical of the Gulf’s heritage. Historically, the Majlis has served as a living space where community members gather to discuss important issues, current events and socialize. As time passed, Majlises became more common and now exist widely in most Gulf households and representing a living space where guests are received, catered to, and entertained. Majlises are often large living spaces, decorated with various types of furniture that embody a strong cultural tradition. More recently, with the advent of pandemic and work-from-home becoming the norm, these living spaces have evolved to become more than just living space to host guests. They are now more commonly used as working spaces.

The Shurouq Collection reinvents the typical Majlis furniture to be more dynamic and functional. It innovates on the long-standing heritage to provide a fresh perspective on how these living spaces can be designed to cater to a wide variety of needs.

In addition to the Majlis living space, this collection was also inspired by local traditional architecture. The typical architectural “arch” evident in Qatari courtyards and windows, were deconstructed and reapplied into the designs and their curvatures. This design element was used as the starting point on the journey to develop the direction of the designs of the Shurouq Collection.



3.2 FROMM. DESIGNERS

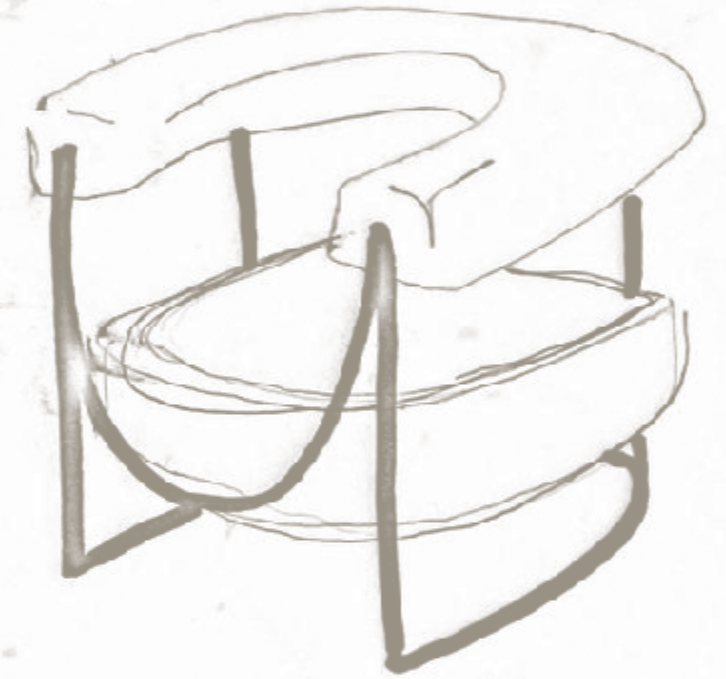
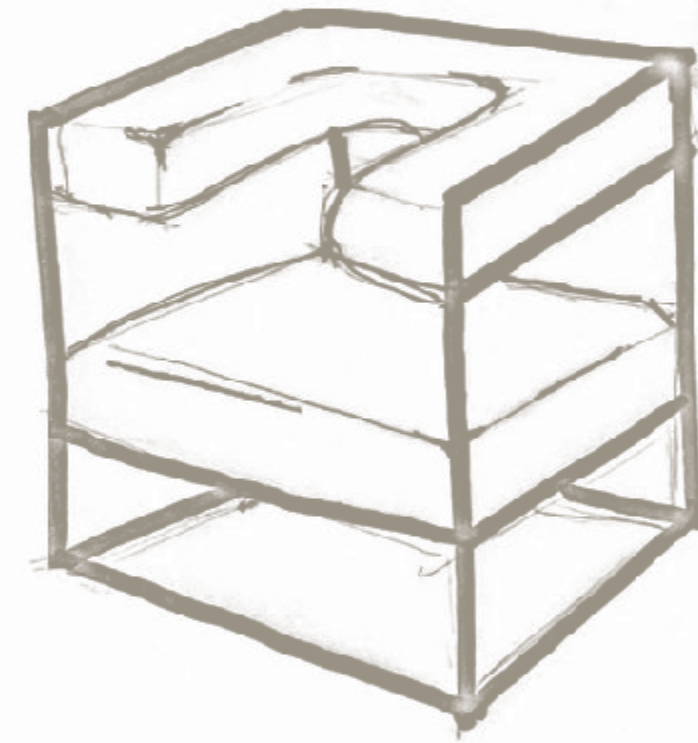
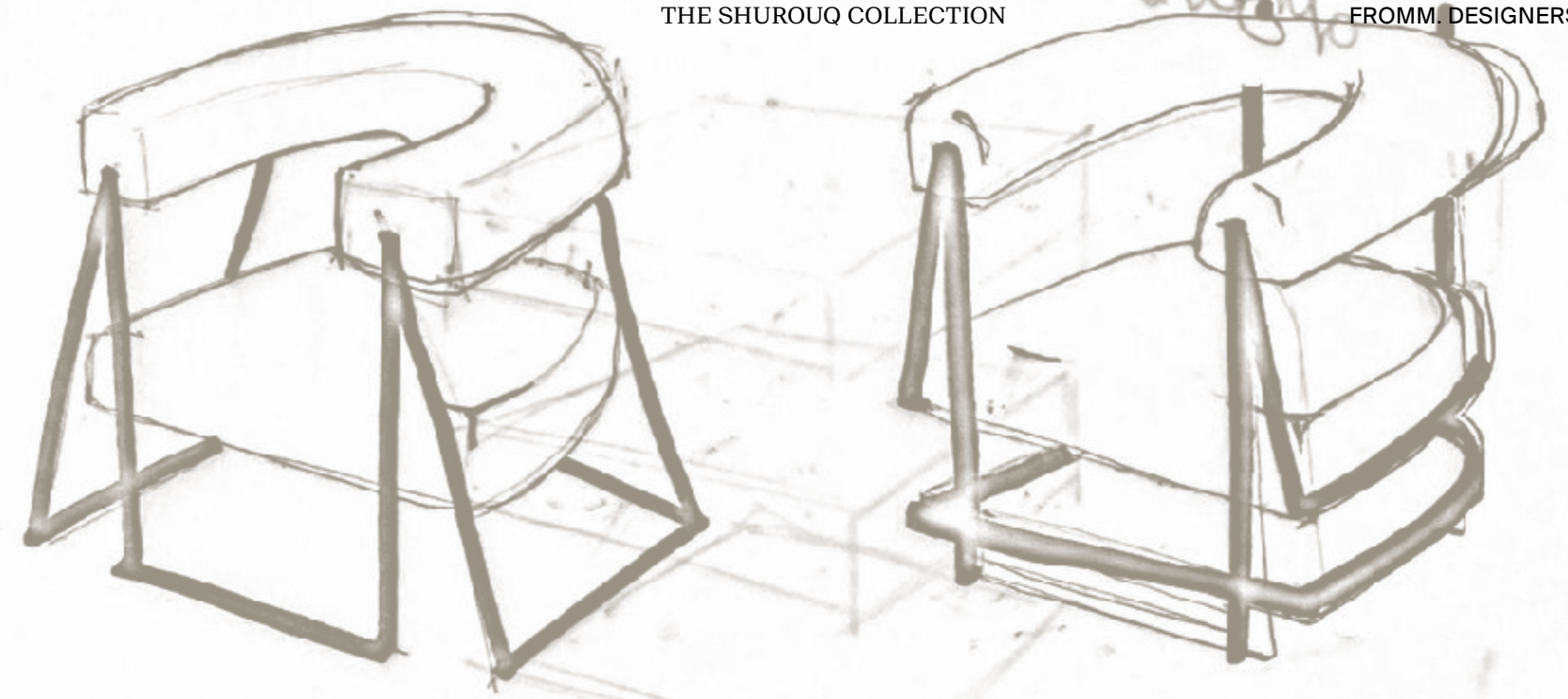

MARYAM AL SUWAIDI

Maryam Al Suwaidi, a Qatari designer, joins the FROMM. Design Team with a strong background. She has completed a bachelor's in fine arts (interior design) and MA in Urban planning and Design, from Virginia Commonwealth University, School of Arts in Qatar. She is currently a Ph.D. candidate in Urban Design.



As a designer, Maryam takes a critical view of social and cultural matters using the philosophy of conceptualism as the primary muse and tool. Al Suwaidi analyzes and utilizes diverse aspects of human evolution of Cultural representations and expressions to form visuals of metaphors or iconologies, establish new conceptually layered installations, and create an abstract dialogue that only the viewer can comprehend through their interpretation.

"My journey with FROMM. was a whole new experience in my artistic career. As a visual designer, I know how to translate my thoughts to artistic visions. But through my collaboration with FROMM., I've learned how to translate those artistic visions into daily practical elements that are not only used as mere furniture pieces but also reflect the artistic beauty of our identity and culture."

SHUA'A ALI

Shua'a Ali, a Qatari self-taught designer joins the FROMM. Design Team with a wealth of experience. In parallel with her background in Computer Science, she developed a passion and interest in art in the early stages of her life while living abroad in various cities, granting her exposure to diverse cultures and traditions.



Shua'a experiments with old and new by placing them in a confrontational dialogue by using tradition and culture as inspirations to retain aspects of cultural identity within the fast-paced globalization challenges. She uses art to share her reflections and experiences on contemporary moments through using various means to interact and communicate with the public. Through conceptual art, Shua'a encourages audiences to question and rethink their own identities and environment within the context of accelerating progress and development in her.

"My creativity has largely fueled my passion for art and design culture. FROMM. has provided me a great platform to take this a step forward by facilitating and guiding me to translate this creativity and diversify my creative practices through multiple artistic mediums."

3.3 THE SHUROUQ COLLECTION



3.3.1 HAIMA' Armchair هَيْمَاءُ

&

HAIMA' Pouf



DESIGNER **MARYAM AL SUWAIDI**

Haima' is an armchair worth a thousand words. Its characterful simple shell is based on a tender embrace. Each part of this piece effortlessly links to the other: from the backrest to the armrests, this piece of furniture was created with comfort as the leading principle.



DIMENSIONS

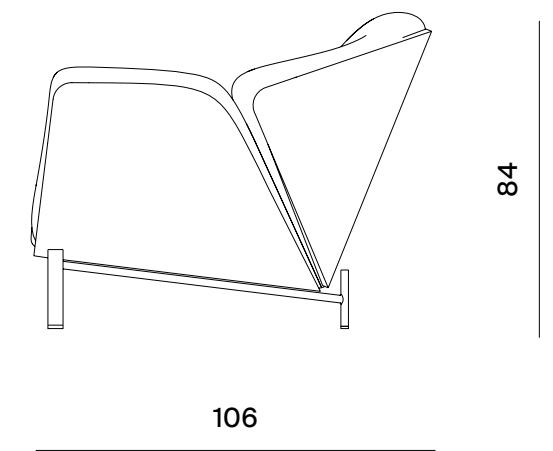
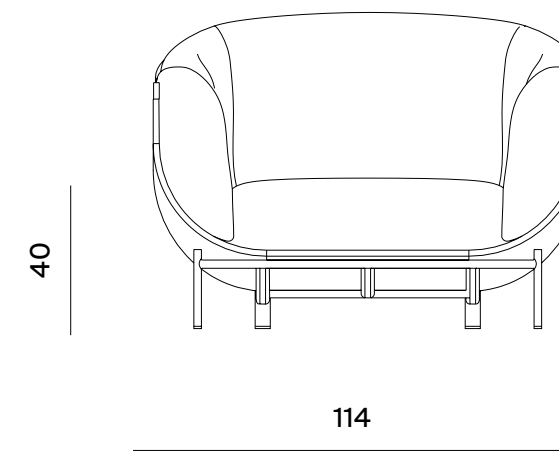

MATERIAL FINISHES

UPHOLSTERY

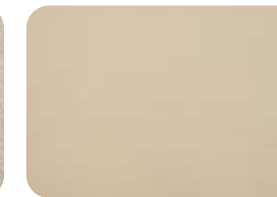
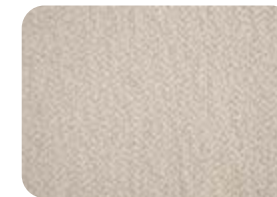

Bouclé
Fabric 1730

Eco-Leather

PADDING MATERIAL FOR THE UPHOLSTERY:
EXPANDED POLYURETHANE COVERED BY SOFT
FIBER MADE FROM RECYCLED BOTTLES.

STRUCTURE - TUBULAR STEEL



FROMM.
Gold color

METAL LIQUID PAINTED (WATER BASED PAINT).

WOOD SHELL



Mw Newwood

CUSTOM PLYWOOD (ALL FSC WOOD ORIGINALLY)
WITH EXTERNAL VENEER. WOOD THICKNESS
CHARACTERIZED BY A PRE-ASSEMBLED WOOD IN
THE MIDDLE, LIGHTER WOOD LAYERS MADE IN
POPLAR WOOD.

DIMENSIONS

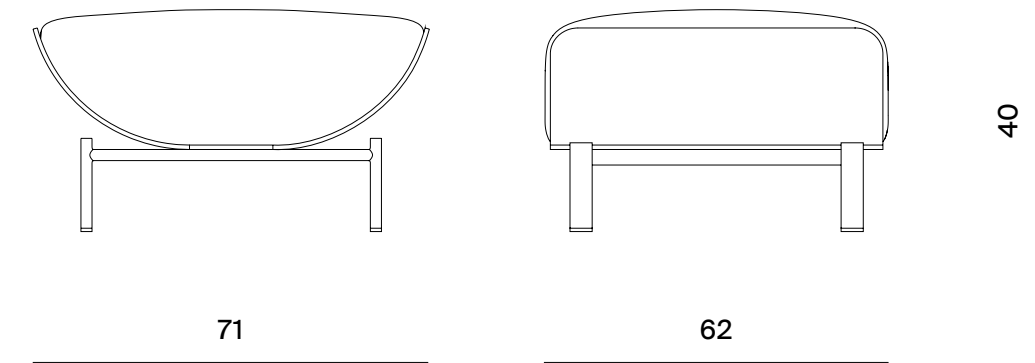

MATERIAL FINISHES

UPHOLSTERY

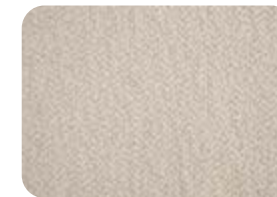

**Bouclé
Fabric 1730**

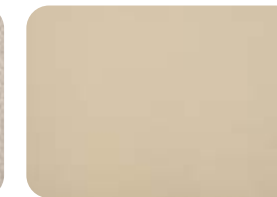

Eco-Leather

PADDING MATERIAL FOR THE UPHOLSTERY:
EXPANDED POLYURETHANE COVERED BY SOFT
FIBER MADE FROM RECYCLED BOTTLES.

STRUCTURE - TUBULAR STEEL



**FROMM.
Gold color**

METAL LIQUID PAINTED (WATER BASED PAINT).

WOOD SHELL



Mw Newood

CUSTOM PLYWOOD (ALL FSC WOOD ORIGINALLY)
WITH EXTERNAL VENEER. WOOD THICKNESS
CHARACTERIZED BY A PRE-ASSEMBLED WOOD IN
THE MIDDLE, LIGHTER WOOD LAYERS MADE IN
POPLAR WOOD.



3.3.2 MAJRA Multifunctional Table مَجْرَى



DESIGNERS **MARYAM AL SUWAIDI
& ELLAQUADRO**

The Majra multifunctional table with Baida' and Haima' create comfortable personal working spaces. It ensures functionality, comfort, accessibility, and purpose.



DIMENSIONS

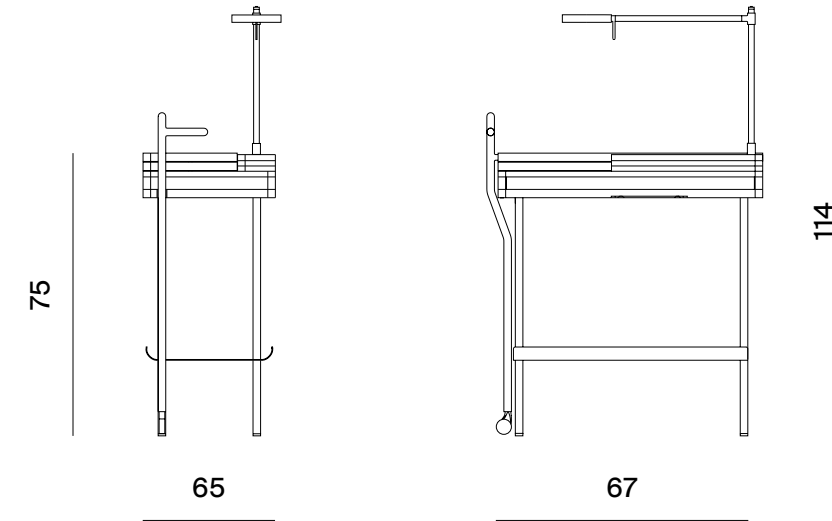

MATERIAL FINISHES

WOOD ELEMENTS



Mw Newood

CUSTOM PLYWOOD (ALL FSC WOOD ORIGINALLY) WITH EXTERNAL VENEER. WOOD THICKNESS CHARACTERIZED BY A PRE-ASSEMBLED WOOD IN THE MIDDLE, LIGHTER WOOD LAYERS MADE IN POPLAR WOOD.

STRUCTURE - ALUMINUM



FROMM.
Gold color
METAL SHEET 20/10.
LIQUID PAINTED (WATER BASED PAINT).

STRUCTURE - TUBULAR STEEL



FROMM.
Gold color
METAL LIQUID PAINTED (WATER BASED PAINT).

3.3.3 BAIDA' Sofa بَيْدَاءِ



DESIGNER **MARYAM AL SUWAIDI**

Baida' sofa exudes confidence from every angle. Inspired by the desert dunes, this piece is characterised by appealing curves and twists. The Baida' sofa brings comfort from corner to corner, thanks to the knowledge of our master craftsmen.



DIMENSIONS

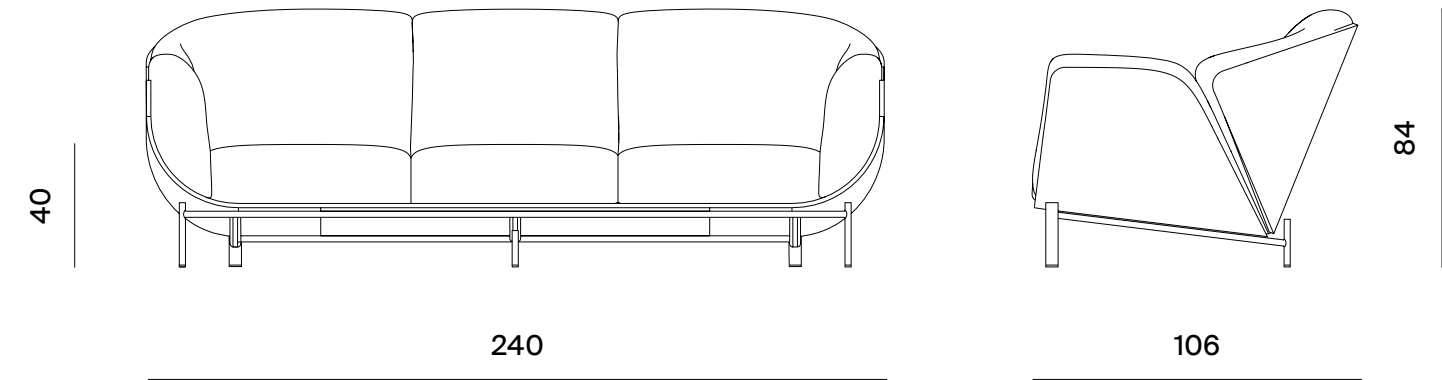

MATERIAL FINISHES

UPHOLSTERY

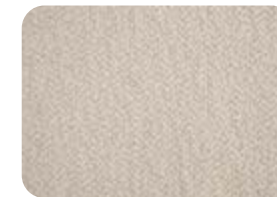

Bouclé
Fabric 1730

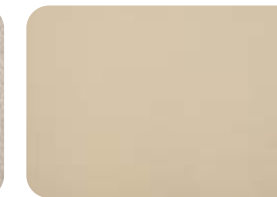

Eco-Leather

CUSHION



Butabù Rafia

PADDING MATERIAL FOR THE UPHOLSTERY:
EXPANDED POLYURETHANE COVERED BY SOFT
FIBER MADE FROM RECYCLED BOTTLES.

STRUCTURE - TUBULAR STEEL



FROMM.
Gold color

METAL LIQUID PAINTED (WATER BASED PAINT).

WOOD SHELL



Mw Newood

CUSTOM PLYWOOD (ALL FSC WOOD ORIGINALLY)
WITH EXTERNAL VENEER. WOOD THICKNESS
CHARACTERIZED BY A PRE-ASSEMBLED WOOD IN
THE MIDDLE, LIGHTER WOOD LAYERS MADE IN
POPLAR WOOD.

3.3.4 MAKTABA Wall Unit مَكْتَبَة



DESIGNER **SHUA'A ALI**

The Maktaba wall unit presents the perfect fusion between aesthetics and functionality. The balanced composition of shelving and cupboard units is the best storage solution for contemporary living spaces.



DIMENSIONS

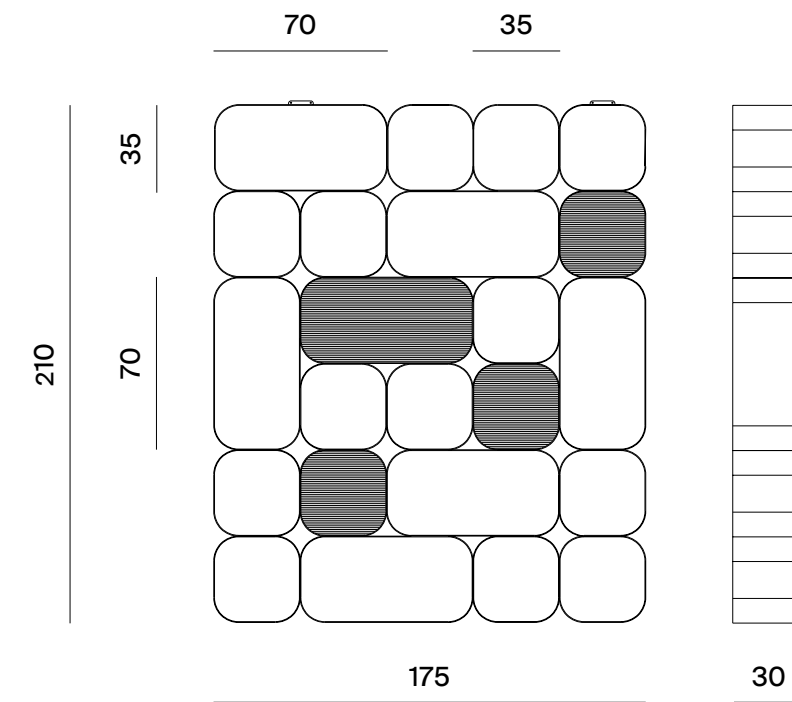

MATERIAL FINISHES

STRUCTURE - ALUMINUM



FROMM.
Gold color
METAL SHEET 30/10.
LIQUID PAINTED (WATER BASED PAINT).

WOOD DOORS



Mw Newood
CUSTOM PLYWOOD (ALL FSC WOOD ORIGINALLY) WITH EXTERNAL VENEER. WOOD THICKNESS CHARACTERIZED BY A PRE-ASSEMBLED WOOD IN THE MIDDLE, LIGHTER WOOD LAYERS MADE IN POPLAR WOOD.

3.3.5 DERJ Console/Desk دَرْج



DESIGNER **SHUA'A ALI**

The Derj piece transforms any living space into your corner for professional ambitions and more. This piece serves as both a decoration and a functional workspace.

DIMENSIONS

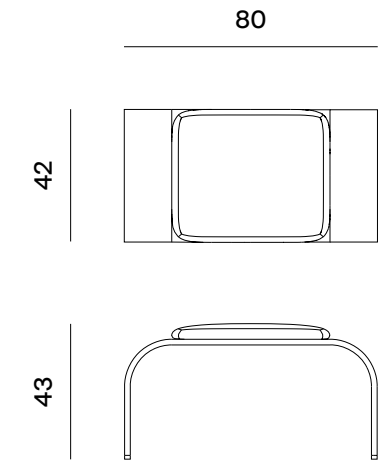
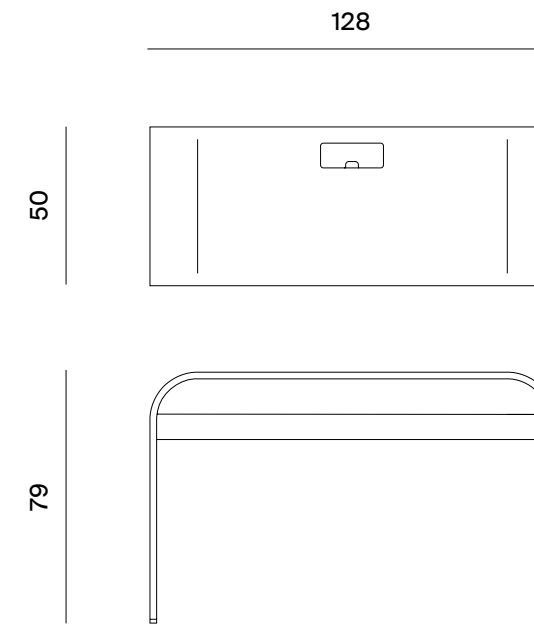

MATERIAL FINISHES

STRUCTURE - ALUMINUM



FROMM.
Gold color

METAL SHEET 30/10,
LIQUID PAINTED (WATER BASED PAINT)

WOOD SHELL



Mw Newood

CUSTOM PLYWOOD (ALL FSC WOOD ORIGINALLY)
WITH EXTERNAL VENEER. WOOD THICKNESS
CHARACTERIZED BY A PRE-ASSEMBLED WOOD IN
THE MIDDLE, LIGHTER WOOD LAYERS MADE IN
POPLAR WOOD.

CUSHION



Butabù Rafia

PATTERN



Shrouq Collection's
Signature Pattern

THE SHUROUQ COLLECTION'S SIGNATURE PATTERN
INSPIRED BY TRADITIONAL PIGEON TOWERS.



3.3.6 MAIZ Coffee Table مَائِز



DESIGNER **SHUA'A ALI**

Maiz blurs the lines between bold and simplistic to create a minimalistic expression of a coffee table that is both elegant and functional. The built-in concrete box serves as a space that can hold various objects and doubles as an incense burner, a cornerstone to Arab hospitality.

DIMENSIONS

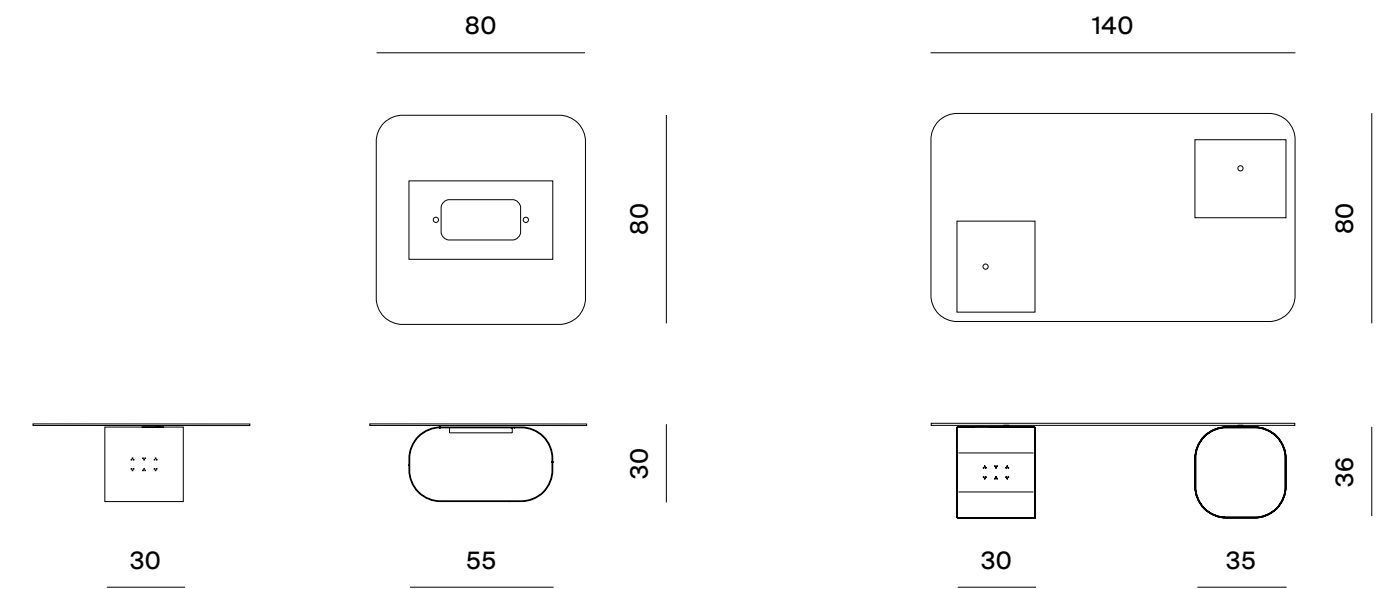

MATERIAL FINISHES

STRUCTURE - ALUMINUM



FROMM.
Gold color
METAL SHEET 30/10,
LIQUID PAINTED (WATER BASED PAINT)

CEMENT

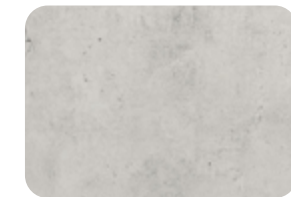

Off-white color
LIGHT TEXTURED

TABLE TOP



Frosted Bronze Glass
FROSTED GLASS - 8mm

PATTERN



Shurouq Collection's - Signature Pattern
THREE PERFORATIONS THAT FORM THE SHUROUQ COLLECTION'S SIGNATURE PATTERN INSPIRED BY TRADITIONAL PIGEON TOWERS.



3.3.7 TAWLA Side Table طاولة



DESIGNER SHUA'A ALI

The Tawla piece is simplicity at its best. A smooth surface at just the right height designed to complement any living space. This table is intended to accessorize interiors discreetly or take center stage.

DIMENSIONS

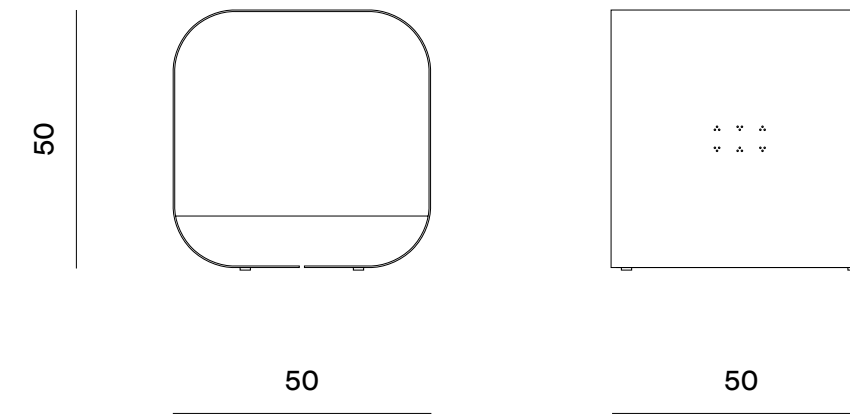

MATERIAL FINISHES

STRUCTURE - ALUMINUM



FROMM.
Gold color
METAL SHEET 30/10,
LIQUID PAINTED (WATER BASED PAINT)

CEMENT

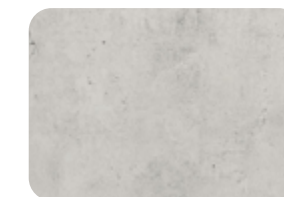

Off-white color
LIGHT TEXTURED

PATTERN



Shurouq Collection's
Signature Pattern
THREE PERFORATIONS THAT FORM THE
SHUROUQ COLLECTION'S SIGNATURE PATTERN
INSPIRED BY TRADITIONAL PIGEON TOWERS.



3.3.8 LAITE Floor lamp لَيْتَة

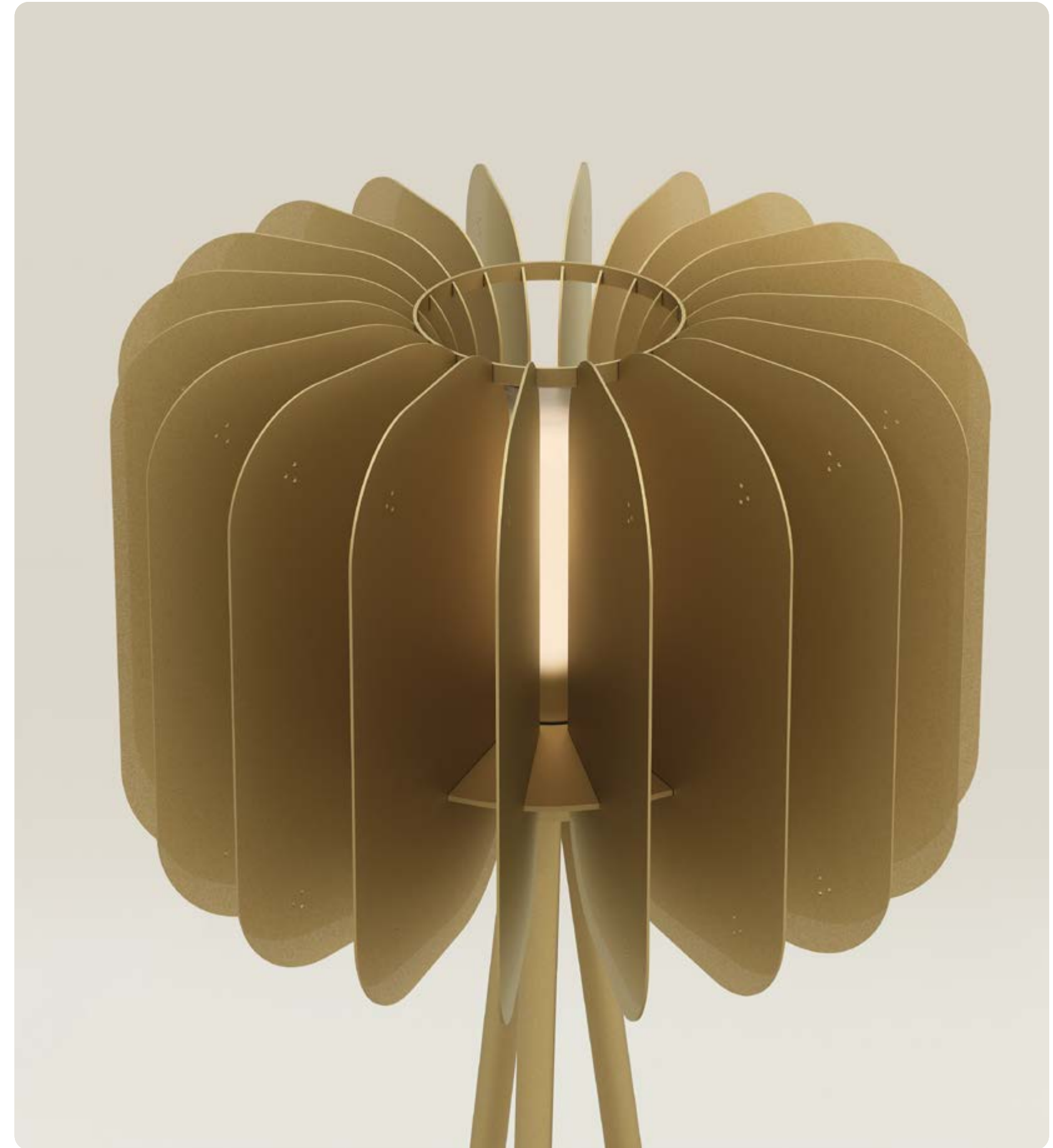

DESIGNERS **SHUA'A ALI & ELLAQUADRO**

Immaculately designed, this piece lights up any room and makes a statement doing so. A round top defines the aesthetics of the lamp, while providing a useful tray for small objects.



DIMENSIONS

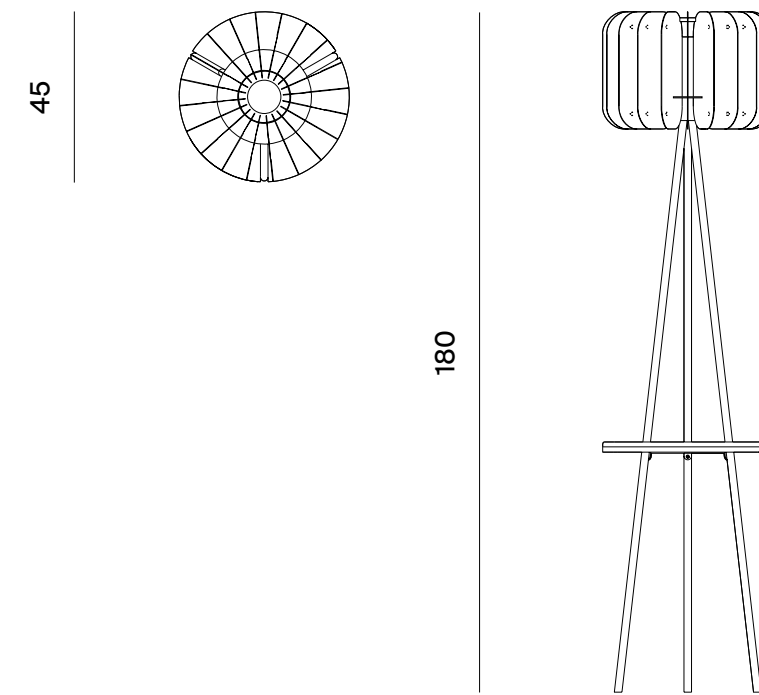

MATERIAL FINISHES

STRUCTURE - ALUMINUM



FROMM.
Gold color
METAL SHEET 30/10, 20/10, 15/10.
LIQUID PAINTED (WATER BASED PAINT).

STRUCTURE - TUBULAR STEEL



FROMM.
Gold color
METAL LIQUID PAINTED (WATER BASED PAINT).

WOOD TRAY



Mw Newood

CUSTOM PLYWOOD (ALL FSC WOOD ORIGINALLY) WITH EXTERNAL VENEER. WOOD THICKNESS CHARACTERIZED BY A PRE-ASSEMBLED WOOD IN THE MIDDLE, LIGHTER WOOD LAYERS MADE IN POPLAR WOOD.

PATTERN



Shurouq Collection's - Signature Pattern

THREE PERFORATIONS THAT FORM THE SHUROUQ COLLECTION'S SIGNATURE PATTERN INSPIRED BY TRADITIONAL PIGEON TOWERS.

4

FROMM. END



4.1 CONCLUSION

Through the Shurouq Collection, FROMM. has interpreted Qatari heritage and provided a contemporary, international perspective on how it can apply to living spaces. Starting in Milan as the capital of design culture, part of our mission is not only to celebrate our Qatari designers but provide them with the backing to create collections and pieces rooted in the ideal fusion of design and manufacturing for their future endeavors.

Heritage innovation is at the heart of everything FROMM. does, and the Shurouq Collection is a testament to this objective. Living in an age of globalization and cultural assimilation, collections like the Shurouq Collection aim to preserve culture in a unique way that is both mindful of tradition and internationally appealing.

Through this collection, we strived to document and break down the FROMM. Design Process to showcase the hard work, dedication, and impactful labour behind each piece in this collection. We hope that by removing this veil and enabling this transparency, we will inspire aspiring designers first and the wider industry second.

In the short term, FROMM. is looking to further establish and optimize our platform to empower designers and unlock their full potential. Moreover, FROMM. is looking further educate the global design industry on our local heritage through design as a medium.

In the long term, FROMM. aims to expand the business outside Doha and Milan, include more designers from the region, and be a brand synonymous with Design culture. We hope to continue to create collections and pieces that have a strong, global impact beyond materials, fabrics, colors, and finishes.

4.2

MEET THE FROMM. TEAM



Alia Rachid
Founder & CEO



Luca Fois
Creative Advisor



Fiorella Villa
Brand & Design Consultant



Mohamed Fayek
Business Development



Dana Said
Brand Manager



Matteo Squaiella
Design Manager



Omaira Amin
General Design Coordinator



Laura Tardella
Graphic & Design



Amin Ahmed
Marketing Manager



Petra Tikulin
Project Manager (Milan Showroom)

4.3 CONTACTS US

WEBSITE
INSTAGRAM
EMAIL

www.from-m.com
fromm.qa
info@from-m.com

FROMM. HEADQUARTER & LAB

M7, Fourth Floor, Msheireb, Doha - Qatar
P.O.Box: 301377

FROMM. SHOWROOM

Via Savona, 35
20144, Milan - Italy

COLOPHON

AUTHORS

Amin Ahmed
Dana Said
Omaima Amin
Matteo Squaiella
Laura Tardella

CREATIVE DIRECTION

Manitu Studio

GRAPHIC DESIGN

Davide Somaschini

RENDERS

Numen Studio

CONTRIBUTORS

Alia Rachid
Luca Fois
Fiorella Villa
Bidayat
Mohamed Fayek

TRANSLATORS

Dana Said
Omaima Amin

PRINTER

TIPO&grafia
info@tipoegrafia.it
Via Baracca, 43
22063, Cantù (CO) - Italy

All Content Copyright, Rights Reserved. © 2022 FROMM.

All copyright, design rights and other intellectual property rights in our designs and products and in all content included in this catalogue (including, but not limited to, logos, images, photos, designs, graphics and text), unless otherwise stated, are and will remain the property of FROMM. and as such are protected by international copyright and other intellectual property laws. Any reproduction, copying, transmission, editing, distribution, exhibition, release, broadcast and/or usage in any other way in whole or in part of the content included in this catalogue (including, but not limited to, logos, images, photos, designs, graphics and text) without prior consent of FROMM. is strictly prohibited and any such action establishes liability for legal action by FROMM. All content featured in this catalogue are offered for individual or commercial information only and as such are offered on a 'as is' basis. FROMM. reserves the right to modify the designs and products in this catalogue, without any prior notice.

FROMM. is a design platform and company launched between Qatar and Italy to create the ideal fusion of Design and Manufacturing, connecting the local, Italian and international design communities to the global market.