

## DIMENSIONS

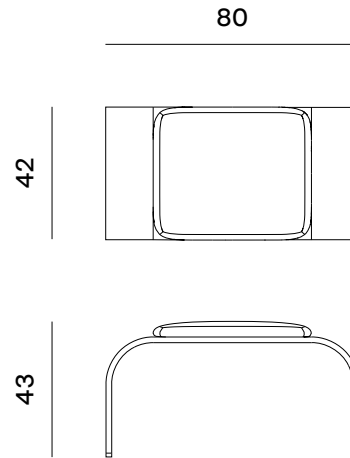

## MATERIAL FINISHES

### STRUCTURE - ALUMINUM

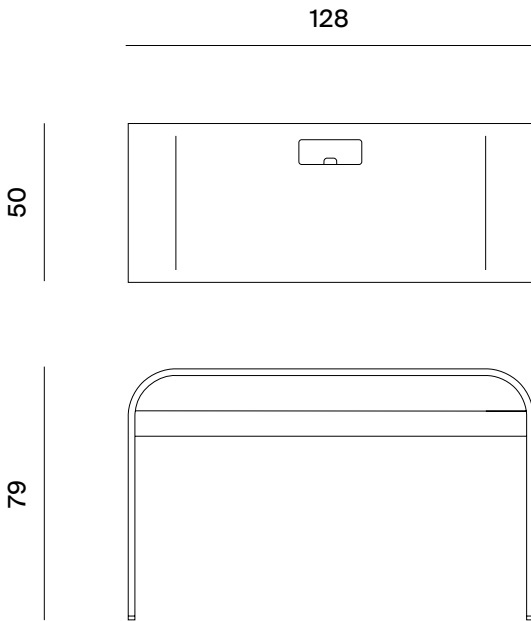

FROMM.  
Gold color

METAL SHEET 30/10,  
LIQUID PAINTED (WATER BASED PAINT)

### WOOD SHELL



Mw Newood

CUSTOM PLYWOOD (ALL FSC WOOD ORIGINALLY)  
WITH EXTERNAL VENEER. WOOD THICKNESS  
CHARACTERIZED BY A PRE-ASSEMBLED WOOD IN  
THE MIDDLE, LIGHTER WOOD LAYERS MADE IN  
POPLAR WOOD.

### CUSHION

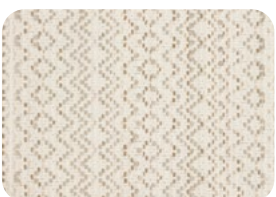

Butabù Rafia

### PATTERN



Shrouq Collection's  
Signature Pattern

THE SHUROUQ COLLECTION'S SIGNATURE PATTERN  
INSPIRED BY TRADITIONAL PIGEON TOWERS.